

Specifications
 Current Rating: 1.0A AC/DC
 Voltage Rating: 250V AC/DC
 Contact Resistance: 30m ohm. Max
 Insulation Resistance: 1000Mohm min
 Withstanding Voltage: 250V(r.m.s) For one Minute
 Operating Temperature Range: -40°C to 85°C
 Materials:

Insulator: High Temp. Plastic (LCP UL94V-0)
 Color: Natural Color

Contact: Phosphor Bronze
 Plated: Gold Plated

How To Order:

BBS10-XXG-535

Total Height
 G: Gold Plated
 No. of Positions
 S: Socket

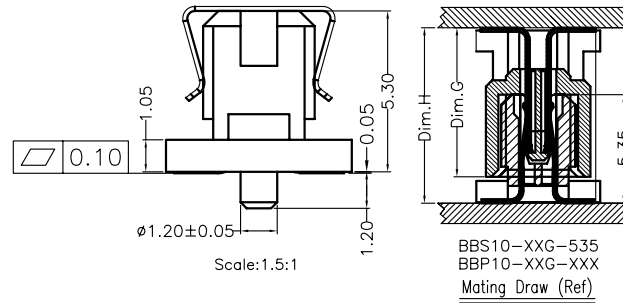
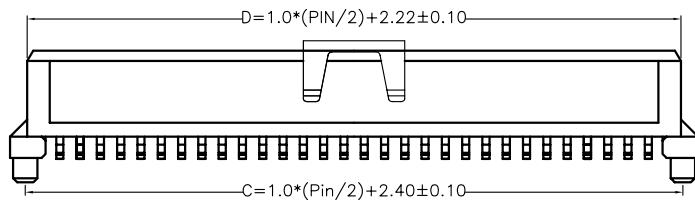

BBS10-XXG-535
 BBP10-XXG-XXX
 Mating Draw (Ref)

Dimensions :

Number of Position	A	B	C	D	Number of Position	A	B	C	D
20	13.90	9.00	12.40	12.22	80	43.90	39.00	42.40	42.22
30	18.90	14.00	17.40	17.22	84	45.90	41.00	44.40	44.22
40	23.90	19.00	22.40	22.22	90	48.90	44.00	47.40	47.22
50	28.90	24.00	27.40	27.22	100	53.90	49.00	52.40	52.22
60	33.90	29.00	32.40	32.22	110	58.90	54.00	57.40	57.22
64	35.90	31.00	34.40	34.22	120	63.90	59.00	62.40	62.22
70	38.90	34.00	37.40	37.22					

**Mating Dimension :

P/N(Socket)	P/N(Plug)	Socket Height Dim G	Mating Height Dim H
BBS10-XXG-535	BBP10-XXG-635	6.35	7.65
BBS10-XXG-535	BBP10-XXG-735	7.35	8.65
BBS10-XXG-535	BBP10-XXG-835	8.35	9.65

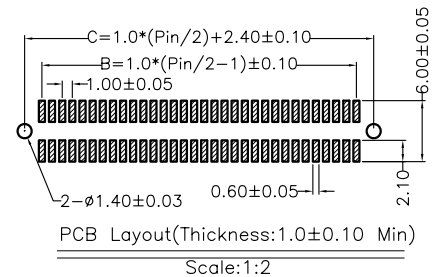

F				DRAWN: Ken	GENERAL TOLERANCE: .X=±0.20 .XX=±0.15	HOYATO 东莞好亚通电子厂 Connector supplies
E						
D				CHECKED: Lily Chou	UNIT: MM	DESCRIPTION: 1.0mm Board To Board Socket 5.35mm Height
C						
B				APPROVAL: Chao Peng	SCALE: 1:1	SIZE A4
A	01-SEP-2009	(PC0001)	Ken			
REV	DATE	FILE	BY	PROJECTION:	SHEET: 1 / 1	PART NO: BBS10-XXG-535